

CTD16-960

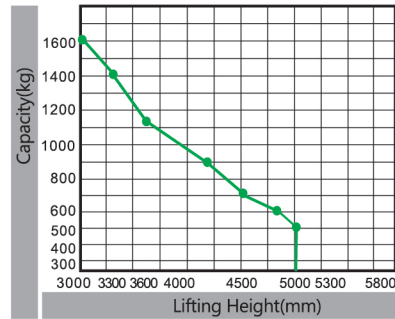

Load Curve



● CTD16-960

		CTD16-960	
Model		CTD16-960	
Loading capacity	kg lb	1600	3500
Mast type		Full free 3-stage Straddle	
Type		Straddle	
Load center	mm in	600	24
Wheel base	mm in	1375	54.1
Operating type		Walkie	
Wheels			
Wheels type		PU	PU
Wheel quantity driving wheel/ balance wheel/ bearing wheel		1/2/4	1/2/4
Dimension			
Lift height	mm in	3700/3900/4200/4500/4700/5000	145/153/165/177/185/196
Max. extend height	mm in	4200/4400/4700/5000/5200/5500	165.4/173.2/185.0/196.7/204.7/216.5
Mast lowered height	mm in	1800/1900/1985/2085/2135/2235	70.9/74.8/78.1/82.1/84.1/88.0
Min. fork lowered height	mm in	55	2.2
Fork length	mm in	1070	42
Fork width	mm in	100	3.9
Fork thickness	mm in	40	1.6
Overall length	mm in	2073/2493	81.6/98.1
Overall width	mm in	1470	57.9
Min. turning radius	mm in	1630/2040	64.2/80.3
Min. aisle width for pallets 800×1200	mm in	2230/2625	87.8/103.3
Min. aisle width for pallets 1000×1200	mm in	2260/2650	89.0/104.3
Min. ground clearance	mm in	50	2
Performance			
Travel speed, laden/ unladen	km/h mph	6/6	3.7/3.7
Lift speed, laden/ unladen	mm/s in/s	130/180	5.1/7.1
Lowering speed, laden/ unladen	mm/s in/s	100/200	3.9/7.9
Gradeability, laden/ unladen	% %	6/8	6/8
Electrical configuration			
Drive motor	kW hp	AC 1.5	AC 2.0
Lift motor	kW hp	DC 3	DC 4.0
Steering motor	kW hp	DC 0.15	DC 0.2
Battery voltage/ capacity	V/Ah V/Ah	24/280	24/280
Brake		Electromagnetic / Regenerative	
Controller		ZAPI	
Weight			
Battery weight	kg lb	235	517
Service weight with battery	kg lb	1577	3470

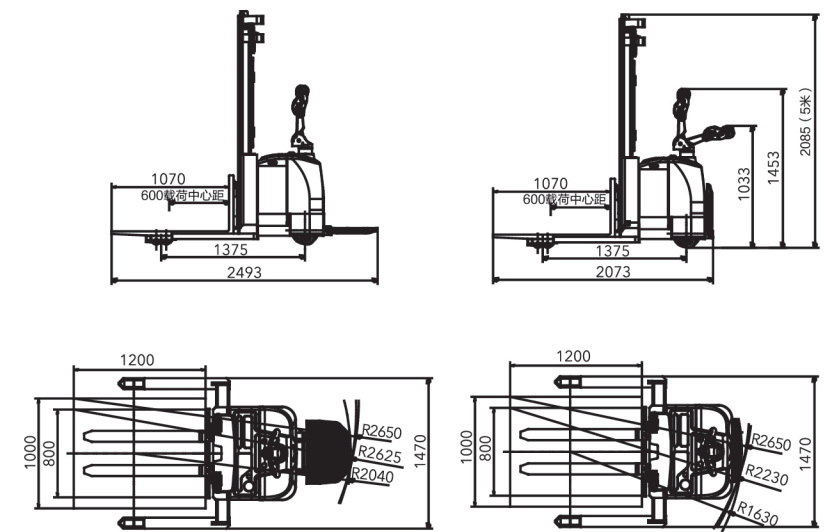

Characteristics

- AC/EPS
- Automatically speed decelerates while at high lifting position.
- Steering automatic deceleration.
- USA CURTIS controller.
- Forks outside width:200-812mm.
- Option: Lithium battery.